

FACT² Excellence Award Winner: Anurag Purwar

Recognition given for consistently superior professional achievement

Mechanical Engineering Professor, Anurag Purwar, is the 2018 recipient of SUNY's FACT² Excellence in Instruction Award. The decision for honoring Professor Purwar was based on his innate ability to incorporate technology into the classroom to further the curriculum. It has been determined by the Faculty Advisory Council on Teaching and Technology (FACT²) that he captivates students using innovative strategies that can be applied in other settings.



The FACT² Excellence in Instruction and Excellence in Instructional Support Awards are system-level honors conferred to acknowledge and provide system-wide recognition for consistently professional achievement and to encourage the ongoing pursuit of excellence.



The Council is an advisory committee to the SUNY provost, comprised of employees and students across the state universities and community colleges of New York. The Council is a resource and advocates for university stakeholders "in the use of technology in service of pedagogy and research." Annually, they honor two SUNY faculty, one in State-Operated and Statutory Campuses, and another in community colleges.

In Prof. Purwar's teaching statement, or "learning statement", as he humbly references in his submission to FACT², he explains that his teaching style is based on the Socratic method of inquiry-based learning. "[Students] learn through active enquiry and critical thinking and the teacher learns with them as well," he elaborates. This engaging style of teaching has led to an increase in class size and student participation in Prof. Purwar's freshman Mechanical Engineering Innovation course. ABET-based assessments of his students' work have documented improved learning outcomes in knowledge and innovative thinking.

In hearing the results of the FACT² award, Jeff Ge, chair and professor of Stony Brook University's mechanical engineering department, was proud but not surprised. He stated, "Prof. Purwar developed an exemplary blended course for Freshman Design Innovation that integrates

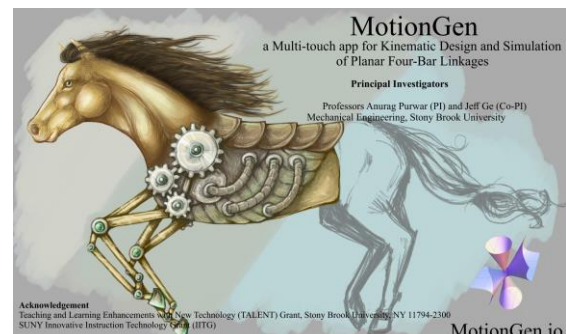

hands-on experience, online learning, and student use of emerging technologies that attracted students from many disciplines across campus. His success in online offering of MEC 262 has attracted students from eleven universities. It is simply amazing that he has been able to develop award-winning instructional innovations on top of his research accomplishments and his role as our department's coordinator for Strategic Partnership in Research (SPIR). Prof. Purwar's award is another example of Stony Brook's success in harnessing the creativity of its research faculty to provide an outstanding education to its undergraduates."

Students are equally enthusiastic about Prof. Purwar's instruction. Junior Mechanical Engineering student, Jae An, fondly recalls his Freshman Innovation Design class, "Prof. Purwar's creative approach in teaching has allowed students to learn far beyond the textbook. He challenges students to go outside of their comfort zone. Although his design project was challenging, he provided students with the resources to succeed. In doing this, he has inspired many students to follow their engineering dreams."

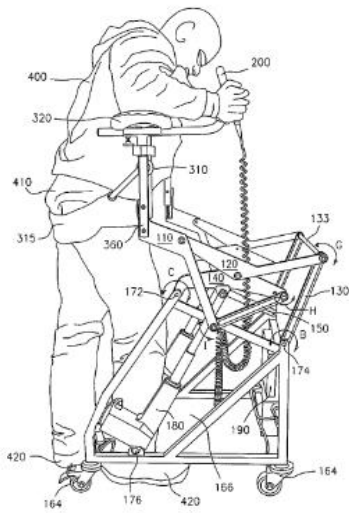

This is one of many accolades that Prof. Purwar has received during his tenure with the Mechanical Engineering department. He has received the Presidential Award for Excellence in Teaching from Stony Brook University, the A.T. Yang award for the best paper in Theoretical Kinematics, and the MSC Software Simulation award. He was a member of the ASME Mechanism and Robotics committee, serving as the Program Chair and the Conference Chair in 2014 and 2015, respectively. He also

served as a conference chair for the prestigious ASME International Design Engineering and Technical Conferences (IDETC) in 2016. Most notably, Prof. Purwar utilized a SUNY Research Foundation Technology Accelerator Fund award to develop a multifunctional Sit-to-Stand-Walker assistive device, which won the 2016 SAE Top 100 Create the Future award. The device is now being commercially marketed and is generating royalty revenue for the university.

The FACT² Excellence Award will be presented to Prof. Purwar at the SUNY Conference on Instruction and Technology (CIT) in May, during which he will present on his innovative use of technology in teaching and learning.

See also:

1. <http://www.motiongen.io>
2. <http://tinyurl.com/mec101f17>